

Date:	Approved:
Type:	
Fixture:	
Project:	

3.5" LED Recessed Housings

LS-350IC

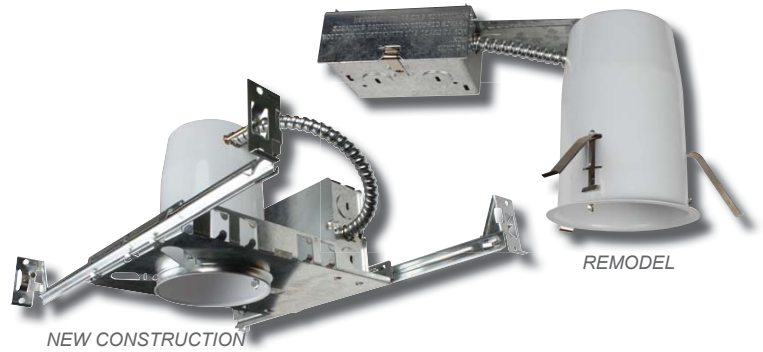

STANDARD



APPLICATIONS

- 3.5" recessed cans for new construction as well as remodel applications.
- Dedicated housings for LED trims/modules.

ILLUMINATION

- Lumen output dependant upon LED trim/module used.

ELECTRICAL

- 2-pin snap-on connector for easy connection to LED trims/modules.

MOUNTING

- Bar hangers on new construction model are adjustable from 13 5/8" to 25" and can be repositioned 90° on plaster frame.
- Four clips on remodel cans provided to secure to housing and accommodate 1/2" and 5/8" ceilings.
- Pre-installed real nail on new model cans easily installs in regular and engineered lumber.

HOUSING

- Galvanized steel construction.
- Contains one 1 1/8", six 7/8" knockouts and four romex pryouts with stain relief.
- Housing on new construction model can be removed from frame to provide access to the junction box.

WARRANTY/LISTING

- cULus listed for damp locations.
- Meets State of California Title 24 requirements.
- Five year warranty.
- Certified under ASTM-E283 for air tight construction.

DIMENSIONS

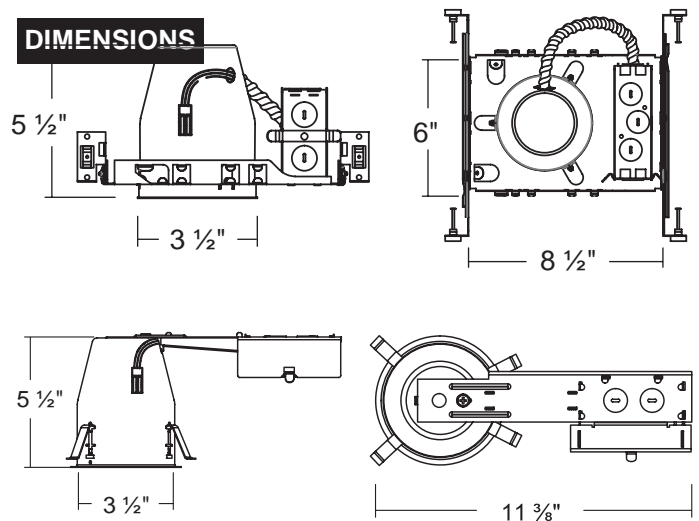

ORDERING INFORMATION

MODEL	DESCRIPTION
LS-350ICATNND-QN	3 1/2" Dedicated LED IC housing for new construction applications
LS-350ICATRND-Q	3 1/2" Dedicated LED IC housing for remodel applications