

Date:	Approved:
Type:	
Fixture:	
Project:	

2X2 Premium Back-Lit LED Panel LS-PNL2X2PRM

STANDARD



FEATURES

- Available in 3500k (warm/neutral white), 4000k (neutral white) & 5000k (cool white) color temperatures.*
- Long-life LEDs provide at least 144,000 hours of operation with at least 70% of initial lumen output (L₇₀).**
- Provides 4,174 to 4,293 luminaire lumens, and 129 to 134 lumens per watt.*
- Uniform illumination with no visible LED pixilation.
- Universal 120-277 AC voltage (50-60Hz) is standard.
- 0-10vdc dimming capability is standard.
- Power factor > 90.
- Total harmonic distortion < 20%.
- Color rendering index > 80.
- Aluminum frame and steel housing backplate.
- PMMA (polymethyl methacrylate) LED lenses for optimal light distribution, efficiency and longevity.
- Easy installation in new construction or retrofit.
- Standard earthquake clips provide secure installation in grid ceilings.
- Standard mounting options include recessed mounting in grid ceilings, or suspended mounting using attached hanging brackets. For mounting in plaster or other hard ceiling, see Mounting Kits.

* Contact factory for other color temperatures and lumen packages.

** L₇₀ hours are IES TM-21-11 calculated hours.



WARRANTY & LISTINGS

- cULus for damp locations and insulated ceilings (Type IC-rated). Suitable for ambient temperatures from -20°C to 40°C (-4°F to 104°F).
- DLC premium approved.
- Flicker-free per IEEE1789-2015 (no observable adverse effects of flicker at 100% light output level).
- Complies with RoHS (Restriction on Hazardous Substances) requirements.
- Complies with FCC Part 15, class B.
- Complies with EN61000-4-5, surge immunity protection (1kV).
- 5-year warranty of all electronics and housing.

MOUNTING KITS

- Optional Surface Mount Kits (LS-SMKT-22) and Flange Mounting Kits (LS-FLANGEKIT22-ET) provide for installation on plaster or other hard ceilings.
- Optional Cable Mounting Kits (LS-DPNL-CMK) provide additional security, as well as suspended mounting.

DIMENSIONS

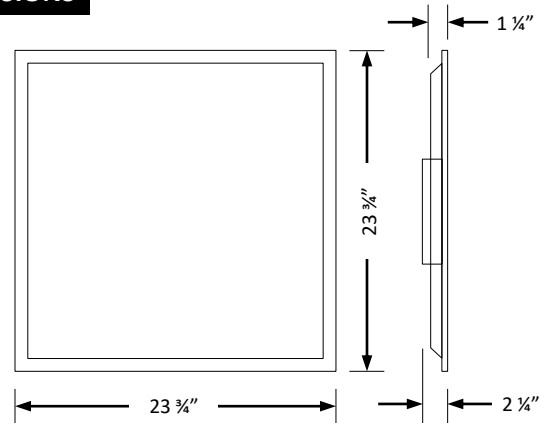

Weight: 5 lbs.

ORDERING INFORMATION

Example: LS-PNL2X2-40L-35K-PRM-EM20

Series	Nominal Lumens	Color Temperature	DLC		Emergency Driver ^{1,2}
LS-PNL2X2	40L	35K	PRM	PREMIUM	EM8
		4K			EM12
		5K			EM16
					EM20
					EM24
					EC8
					EC12
					EC16
					EC20
					EC24
					Blank

¹ See list of emergency drivers (page 2).

² EC emergency drivers are California Energy Commission (CEC) listed.

ELECTRICAL DATA

Model	Color Temperature	CRI ¹	Luminaire Lumens	Luminaire Watts	Lumens Per Watt	Input Voltage ²	Input Current (A)			Power Factor	THD ³	L ₇₀ Hours ⁴
							120V	240V	277V			
LS-PNL2X2-40L-35K-PRM	3500K	> 80	4,174	32	129	120-277	0.27	0.13	0.12	> 90%	< 20%	144,000
LS-PNL2X2-40L-4K-PRM	4000K	> 80	4,234	32	131	120-277	0.27	0.13	0.12	> 90%	< 20%	144,000
LS-PNL2X2-40L-5K-PRM	5000K	> 80	4,293	32	134	120-277	0.27	0.13	0.12	> 90%	< 20%	144,000

¹ Color rendering index.

² All 50-60Hz.

³ Total harmonic distortion.

⁴ L₇₀ refers to the number of hours at which lumen output declines to 70% of the initial level. L₇₀ hours are IES TM-21-11 calculated hours.

PHOTOMETRIC DATA

LS-PNL2X2-40L-5K-PRM

Luminaire Data

Description	2x2 Premium Back Lit LED Panel - 40L 5K
Total Lumens	4,293
Input Wattage	32
Efficacy (lm/W)	134
Spacing Criterion (0-180°)	1.30
Spacing Criterion (90-270°)	1.30

Zonal Lumen Summary

Zone	Lumens	%Fixt
0-20°	502	11.7%
0-30°	1,078	25.1%
0-40°	1,791	41.7%
20-50°	2,054	47.9%
40-70°	2,047	47.7%
0-60°	3,272	76.2%
0-80°	4,182	97.4%
0-90°	4,289	99.9%
90-180°	4	0.1%
0-180°	4,293	100.0%

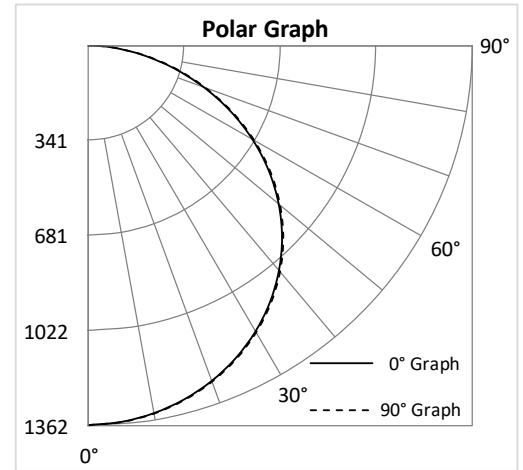

COMPATIBLE EMERGENCY DRIVERS

Emergency Driver Part Number	EM8 / EC8		EM12 / EC12		EM16 / EC16		EM20 / EC20		EM24 / EC24		Runtime
Model	Watts	EM Lumens	Watts	EM Lumens	Watts	EM Lumens	Watts	EM Lumens	Watts	EM Lumens	
LS-PNL2X2-40L-xK	5.0	590	7.8	920	10.7	1263	13.7	1617	17.0	2006	90 MINS.
LS-PNL2X4-50L-xK	5.0	600	7.8	936	10.7	1284	13.7	1644	17.0	2040	
LS-PNL1X4-40L-xK-PRM	5.0	640	7.8	998	10.7	1370	13.7	1754	17.0	2176	
LS-PNL2X2-40L-xK-PRM	5.0	645	7.8	1006	10.7	1380	13.7	1767	17.0	2193	
LS-PNL2X4-50L-xK-PRM	5.0	655	7.8	1022	10.7	1402	13.7	1795	17.0	2227	
LS-PNL2X4-70L-xK-PRM	5.0	655	7.8	1022	10.7	1402	13.7	1795	17.0	2227	

Compatible Dimmers

Manufacture	Model Number	Dimming Range	Load Switching Capacity
Lutron	DVSTV	10%-100%	450W
Leviton	IP710-LFZ	10%-100%	1200W
General Protecht	DMD-LED3-102	10%-100%	600W

MOUNTING MEANS – ORDER SEPERATATLY

- Optional surface mounting kits (LS-SMKT-22) mounts below the ceiling.
- Optional flange mounting kits provide for recessed installation on plaster or other hard ceilings. Attach Flange Mount Kit (LS-FLANGEKIT22-ET) to ceiling joists or other stationary structures, and the panel is mounted flush to the ceiling.
- Optional cable mounting kits provide additional security, as well as suspended mounting. Attach one end of the Cable Mount Kit (LS-PNL-CMK) to luminaire earthquake clips using spring clips, and attach the other end to stationary structures using the adjustable, locking ceiling attachment (see picture below right).

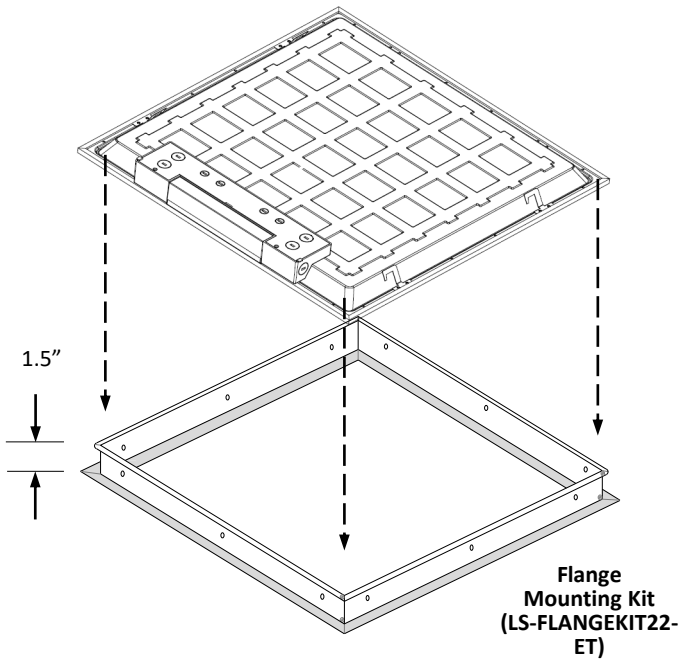
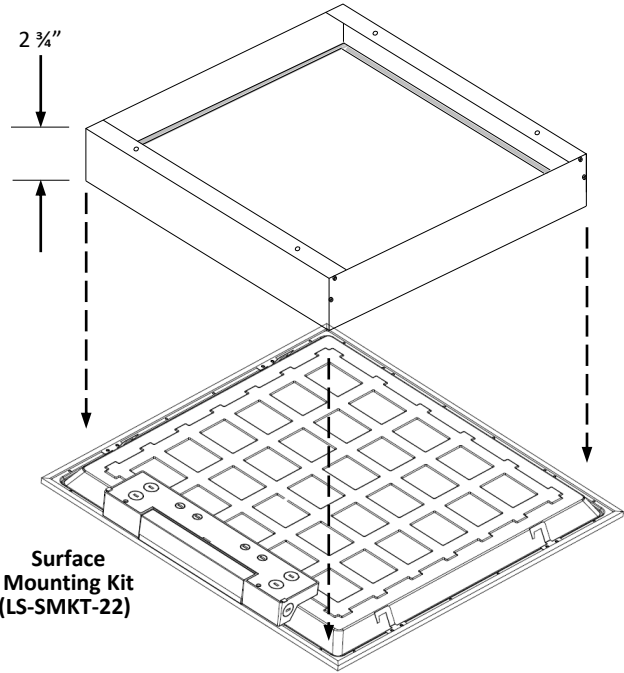

Cable Mounting Kit (LS-PNL-CMK)

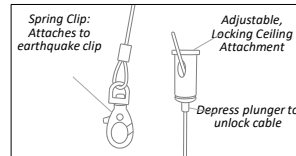

Cable Mount Kit:

- Spring Clip
- Adjustable, locking ceiling attachment